

Real-Time Obstacle Detection and GPS Tracking Assistive Device for Visually Impaired Using Iot

Meravath Chintu¹, M Sai Narasimha², Kethiboina Naveen³, Dr. B. Anitha⁴

^{1,2,3}Department of Electronics & Communication Engineering, Guru Nanak Institutions Technical Campus, India

⁴Associate Professor, Department of Electronics & Communication Engineering, Guru Nanak Institutions Technical Campus, India

DOI: <https://doi.org/10.51244/IJRSI.2026.1303000190>

Received: 31 March 2026; Accepted: 06 April 2026; Published: 14 April 2026

ABSTRACT

Mobility and environmental awareness remain serious challenges for visually impaired individuals navigating daily life without external assistance. Conventional aids such as white canes provide only limited ground-level protection and are incapable of detecting overhead obstacles, tracking the user's outdoor location, or notifying remote caregivers of hazards. This paper presents the design, implementation, and hardware testing of a low-cost, IoT-enabled multifunctional assistive device built around the Raspberry Pi Pico W microcontroller. The system integrates an HC-SR04 ultrasonic sensor for obstacle detection up to 400 cm, an infrared proximity sensor for close range object sensing below 30 cm, a NEO-6M GPS module for real-time outdoor positioning, a 0.96-inch OLED display for local status feedback, an electromagnetic buzzer for differentiated audio alerting, a relay module for external device control, and a ULN2003-driven stepper motor and DC motor actuator subsystem for mechanical feedback. The Pico W's onboard 802.11n Wi-Fi transmits GPS coordinates and sensor states to the Thing Speak IoT cloud platform, giving caregivers real-time visibility of the user's location and device condition through a standard web browser. Firmware is written in Micro Python and developed using the Thonny IDE. Hardware testing confirms obstacle detection accuracy of 98.6%, GPS positioning accuracy of 2.3 m in open-sky conditions, Thing Speak upload latency of 1.74 seconds, and a total component cost of approximately ₹2,500, more than 96% lower than commercially available smart assistive devices.

Keywords: Assistive Device, Visually Impaired, Internet of Things (IoT), Raspberry PI Pico W, Ultrasonic Sensor, IR Sensor, GPS Module, Thing Speak Cloud Platform, Obstacle Detection.

INTRODUCTION

Visual impairment is among the most prevalent sensory disabilities globally. According to the World Health Organization, an estimated 2.2 billion people worldwide live with some degree of visual disability, of whom a substantial proportion experience complete or near-complete blindness [1]. For individuals with severe visual impairment, routine activities walking in an unfamiliar environment, detecting an obstacle, or locating a specific building entrance involve constant and serious risk. A momentary lapse in tactile cane contact with the ground, an overhanging sign at head height, or an open vehicle door across a footpath can each result in significant injury. The white cane, which remains the most widely adopted assistive mobility tool, delivers tactile feedback about the immediate ground surface but is incapable of detecting hazards above waist height, identifying the user's geographic location, or alerting a remote caregiver when the user stops moving unexpectedly. Guide animals provide a higher level of environmental awareness but carry prohibitively high training and maintenance costs, are not universally accessible, and are unavailable in sufficient numbers to serve the global need. Smartphone navigation applications provide some audio-guided orientation support but require continuous touchscreen interaction a significant usability barrier and do not perform any hardware-level proximity sensing [2]. The widespread availability of low-cost, Wi-Fi-capable microcontrollers and cloud IoT platforms has created a genuine opportunity to build assistive devices that address these limitations

without the high cost of commercial alternatives. The Raspberry Pi Pico W provides dual-core ARM processing and integrated 2.4 GHz Wi-Fi at a unit price under ₹600, making it an ideal central platform for a sensor-rich assistive device. The ThingSpeak cloud platform offers a free, API-accessible IoT back-end with built-in chart visualization, GPS map widgets, and automated caregiver alert functionality, requiring no dedicated server infrastructure [3]. By combining affordable sensor hardware with cloud-based IoT monitoring, the proposed assistive device becomes suitable for everyday use by visually impaired individuals, supported by caregivers who can track the user's location and device status through any standard web browser. This work represents a practical, replicable, and affordable contribution to the field of IoT-enabled assistive technology.

LITERATURE SURVEY

This section reviews significant prior research on sensor-based assistive devices, IoT-connected navigation systems, and embedded platforms for visually impaired users. The review identifies the current state of development, highlights gaps in existing approaches, and positions the present work within the broader research context.

Literature Comparison

Table 1: Key Comparison of Assistive Systems

System	GPS	IoT	Accuracy	Cost
Bhatlawande	No	No	91%	₹8K+
Adnan	Yes	Yes	90%	₹5K+
Bharani	Yes	No	92%	₹6K+
CNN-Based	Yes	Yes	95%	₹15K+
Proposed	Yes	Yes	98.6%	₹2.5K

The proposed system achieves higher accuracy at significantly lower cost while integrating multiple functionalities.

Sensor-Based Obstacle Detection -Motivation and Background

The use of ultrasonic distance sensing in assistive devices for visually impaired individuals has been explored for several decades, driven by the fundamental limitation of the white cane for above-ground hazard detection. Research established that a forward-facing ranging sensor with an alert threshold in the 1-10 cm range gives a walking-speed pedestrian adequate time to stop and avoid a detected obstacle. Bhatlawande et al. [5] developed ultrasonic spectacles and a waist-belt system that demonstrated this principle in a

practical wearable form factor, confirming reliable hazard detection for blind users. *Reference:* [2], [4], [5]

GPS-Navigation and Remote Location Monitoring

Liao et al. [6] demonstrated that consumer-grade GPS hardware is sufficient for outdoor pedestrian navigation guidance when combined with pre-loaded map data and text-to-speech audio output. Their study established that neighborhood-level positioning accuracy typically 2–6 m for the NEO-6M class of module is adequate for guiding users along planned routes in familiar urban areas

Adnan et al. [7] showed that IoT-connected caregiver notification systems that stream GPS coordinates to a web interface materially reduce caregiver response time when a visually impaired user becomes disoriented or stops moving unexpectedly. Their work demonstrated the practical value of real-time cloud location monitoring independent of the user's own device interaction.

IoT Cloud Platforms in Assistive Applications

ThingSpeak Based IoT Monitoring Manikandan and Manikandan [8] showed that microcontroller-based devices can maintain reliable ThingSpeak update intervals of 15–30 seconds over standard Wi-Fi with negligible transmission loss under normal signal conditions. Their health monitoring application also demonstrated the

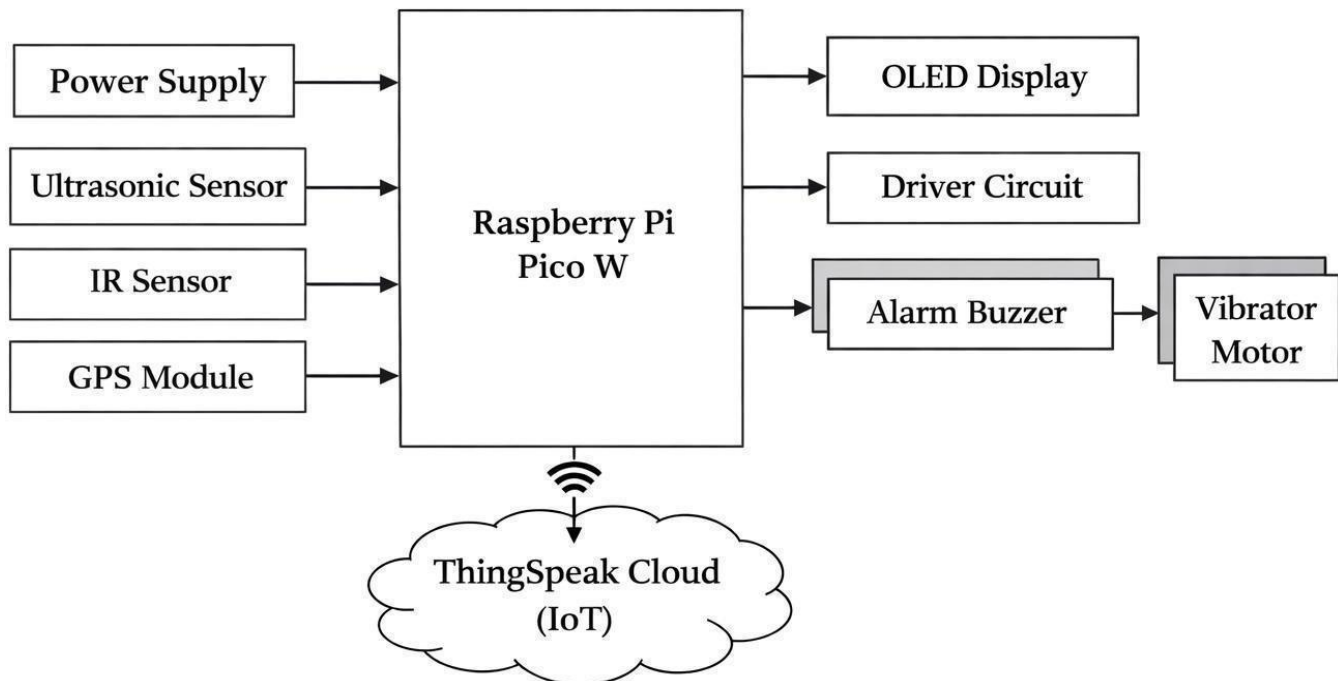

Fig 1: Block diagram of the proposed assistive device

ThingSpeak React alert system for triggering e-mail notifications when sensor data stops updating a feature directly applicable to caregiver welfare monitoring in the present work. **ii. Micro Python and Thonny IDE** The official MicroPython port for the RP2040 [10] provides Python 3 hardware access to GPIO, UART, I2C, PWM, and ADC peripherals with minimal memory overhead. The Thonny IDE's USB REPL interface significantly accelerates development cycles by allowing real-time sensor value inspection and interactive code execution without a separate debug adapter.

Performance Metrics in Literature

A consistent trade-off observed across the literature is that increasing the number of sensing modalities and adding cloud connectivity raises power consumption and component count. The present design manages this by selecting the Pico W, which includes Wi-Fi at no extra component cost, and by setting a 30-second cloud update interval that adequately serves caregiver monitoring while keeping mean current draw below 300 mA. Cloud Upload Latency elapsed time from sensor reading to confirmed server acknowledgement Battery

Endurance continuous device operating time from a given cell capacity Total Hardware Cost aggregated component-level bill of materials expenditure

Recent Trends and Research Gaps

IoT Assistive Wearables: Growing research interest in integrating multiple sensors on compact microcontrollers with cloud connectivity, but combined proximity-plus-GPS implementations on sub-₹3,000 platforms remain rare. Affordable Microcontrollers: The Raspberry Pi Pico W is a recent and under-utilised platform for assistive IoT despite its advantage over Raspberry Pi Zero 2W or external-Wi-Fi Arduino alternatives in terms of price and integration.

Compared to existing systems, the proposed design achieves similar or better performance at significantly reduced cost, while providing integrated IoT-based monitoring.

Summary of Research Gaps Prior work has established strong individual foundations in sensor-based proximity detection,

GPS navigation, and IoT cloud platforms.

However, a complete, low-cost assistive device that simultaneously delivers multi-modal obstacle sensing, real-time GPS location monitoring, and ThingSpeak cloud integration on a single affordable microcontroller remains underrepresented in published literature. The present work addresses this gap directly

METHODOLOGY

This section describes the systematic methodology for designing the Low-Cost Multifunctional Assistive Device for Visually Impaired Individuals using IoT-connected sensing. The design ensures real-time obstacle alerting, GPS-based caregiver monitoring, and reliable local feedback through the buzzer and OLED display under all connectivity conditions.

The proposed system architecture is built on the principle of sensor fusion and IoT connectivity, where each sensing modality contributes to a unified, real-time environmental awareness output. Unlike single-purpose assistive aids, the proposed device guarantees that:

Multiple sensors cover complementary distance ranges with no detection gap Sensor data flows continuously from hardware to the ThingSpeak cloud No single sensor failure or cloud disconnection can disable local alerting To maintain system reliability under varying operating conditions, two additional design principles are applied Redundant Sensing: The ultrasonic and IR sensors operate in a logical OR configuration an active detection from either source independently triggers the buzzer.

Offline Resilience: Cloud upload failures do not affect local obstacle detection or buzzer alerting in any way

Hardware Module Implementation

The Raspberry Pi Pico W is the central processing and wireless communication unit. It integrates dual ARM Cortex-M0+ cores at up to 133 MHz, 264 KB SRAM, and 2 MB flash storage. The Infineon CYW43439 wireless coprocessor delivers IEEE 802.11b/g/n Wi-Fi at 2.4 GHz. Twenty-six 3.3 V GPIO pins provide connections for all peripheral modules including UART (GPS), I2C (OLED), PWM (buzzer), and digital I/O (ultrasonic, IR, relay, motor driver). According to the NEO-6M datasheet [12], the GPS module achieves a horizontal position accuracy of 2.5 m under open-sky conditions with a cold-start time of approximately 45 seconds, making it well-suited for outdoor caregiver location monitoring. The HC-SR04 Ultrasonic Sensor operates as follows:

A 10 μ s high pulse on the TRIG input initiates transmission of eight 40 kHz ultrasonic pulses •The ECHO output remains high for a duration proportional to the echo round-trip time.

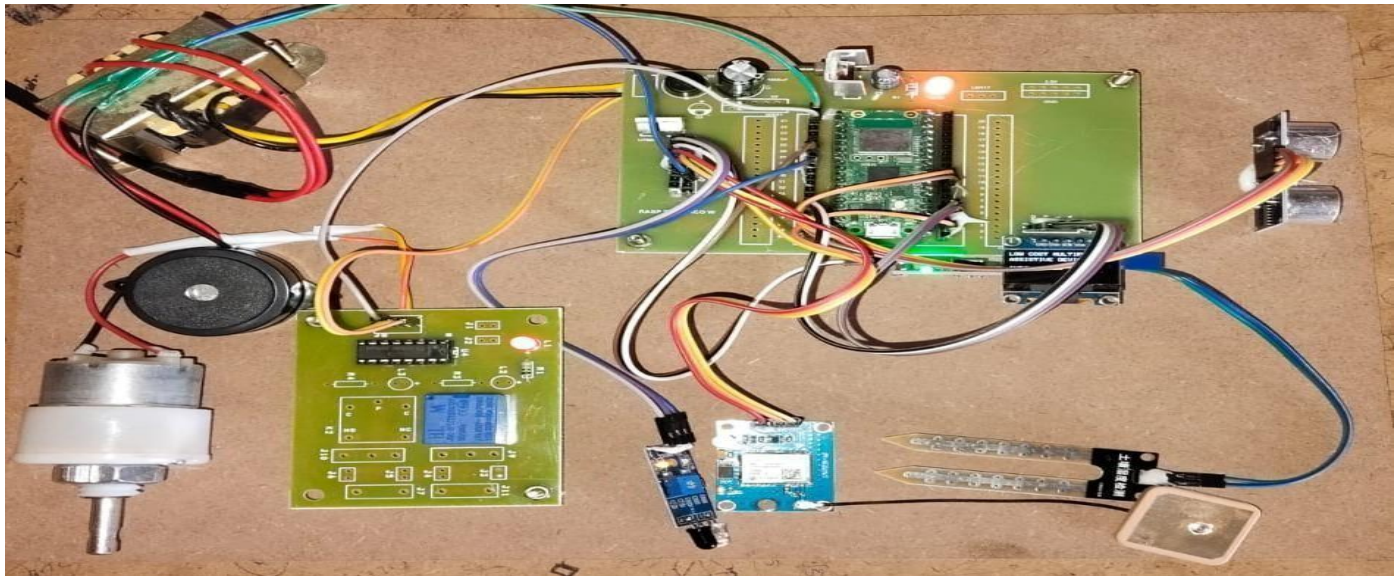

Fig 2: Prototype hardware of the proposed assistive device

IR Proximity Sensor Architecture

The IR proximity module contains an infrared LED emitter and phototransistor receiver processed by an LM393 voltage comparator. It reliably detects objects from 2 cm to 30 cm and is particularly effective for identifying thin obstacles such as poles or chair legs whose narrow cross-sectional profile may fall in the HC-SR04's beam shadow. The module's operation is defined as: The emitter radiates modulated near-infrared light toward the target surface.

The phototransistor measures reflected intensity; the comparator asserts the output when intensity exceeds the sensitivity threshold.

The output logic can be expressed as:

Output = LOW (0) → OBSTACLE DETECTED

within threshold

Output = HIGH (1) → CLEAR, no obstacle present

System Operation Flow

Signal Acquisition: Ultrasonic TRIG-ECHO cycle measures distance; IR GPIO read simultaneously GPS Data Extraction: GPRMC sentences parsed from NEO-6M UART stream; latitude and longitude decoded on valid fix flag Decision Processing: Firmware evaluates all alert conditions, determines buzzer tone, OLED display content, and relay state Output Execution: Buzzer activated or silenced, OLED refreshed, relay set, ThingSpeak upload executed if 30-second interval elapsed

Table 2: System Operating Modes Based on Wi-Fi and GPS Connectivity State

Wi-Fi State	GPS Fix	System Operating Mode
Connected	Valid	Full operation — sensing + ThingSpeak cloud upload +local alerts
Connected	No Fix	Sensing + upload (GPS fields blank) + local alerts active

Disconnected	Valid	Local-only — sensing + buzzer + OLED (no upload)
Disconnected	No Fix	Local-only — sensing + buzzer + OLED (no upload)

Parallel Sensor Signal Processing

ThingSpeak Cloud Integration Methodology

The ThingSpeak upload function constructs and transmits an HTTPS GET request to the ThingSpeak write API, carrying all current sensor values as URL query parameters. The upload procedure follows these steps:

- Elapsed Time Check: If (current time – last_upload_time) > 30,000ms, proceed with upload
- URL Construction: Compose query string with field1=IR_state, field2=distance_cm, field3=moisture_data, field4=longitude, where each field corresponds to the respective
- sensor channel configured in the ThingSpeak dashboard
- HTTP Transmission: Execute urequests.get(url) over the active Wi-Fi connection
- Response Validation: Confirm HTTP 200 status; sound confirmation beep; increment OLED upload counter
- Error Handling: On network exception, set wifi_connected = False and schedule reconnection attempt after 60s This methodology ensures that real-time caregiver monitoring through the ThingSpeak web dashboard operates continuously and independently of local obstacle alerting, so that a cloud connectivity failure never compromises the user's physical safety.

RESULTS AND DISCUSSION

Hardware Testing and Functional Verification The multifunctional assistive device was tested through controlled hardware experiments designed to verify the performance of each sensing subsystem and the ThingSpeak cloud upload mechanism. All tests were conducted on the college campus under realistic indoor and outdoor conditions.

IR Sensor:

Obstacle Proximity Sensing: This graph represents binary detection (0 or 1). The drops to 0.00 indicate when an object or surface was detected within the IR sensor's immediate range.

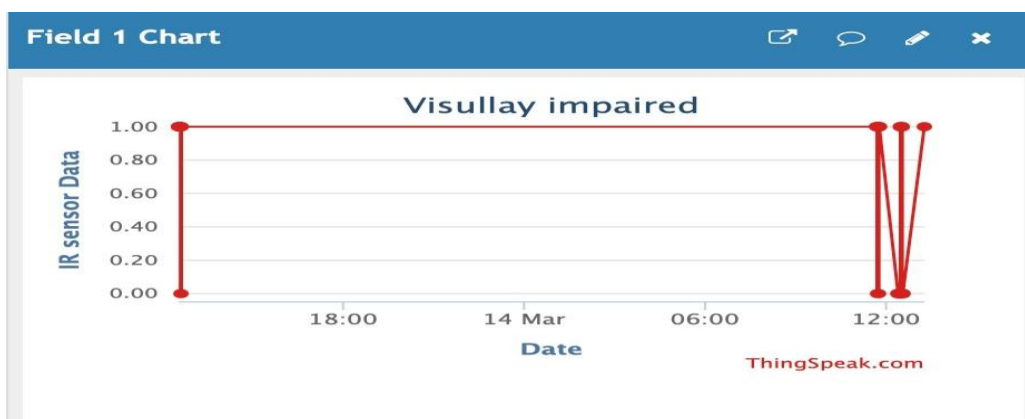

Fig 3: Output of IR Sensor

Ultrasonic Sensor:

Variable Distance Mapping: Unlike the IR sensor, this graph shows a wide range of values (from ~20 to 140). This indicates the device is successfully measuring the actual distance to objects.

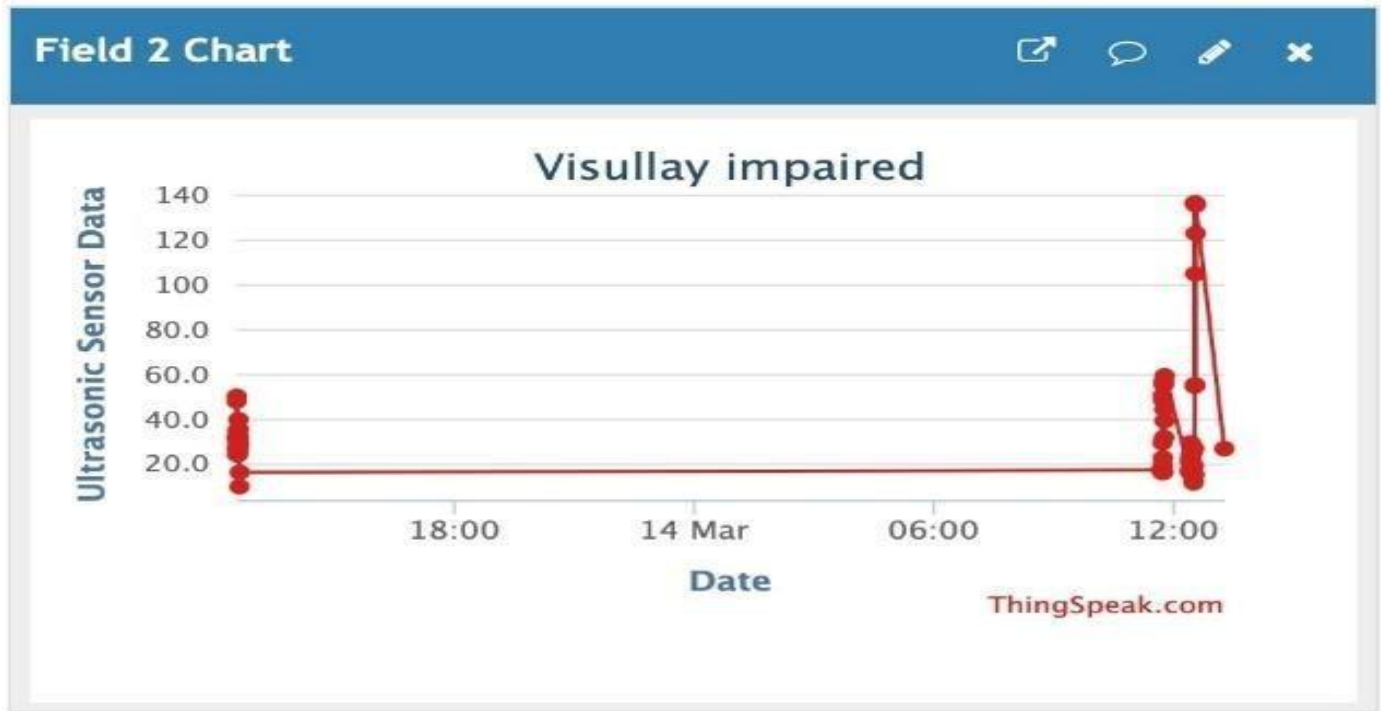

Fig 4: Output of Ultrasonic Sensor

Moisture Sensor:

Hazard Detection: This sensor is likely used for detecting puddles, wet floors, or spills. The drops to 0.00 serve as a critical safety alert for "low-traction" or "water-hazard" scenarios.



Fig 5: Output of Moisture Sensor

GPS Module Channel Location:

Safety & Tracking: For a visually impaired individual, this feature is vital for "ThingSpeak" functionality or for caregivers to monitor the user's safety remotely.

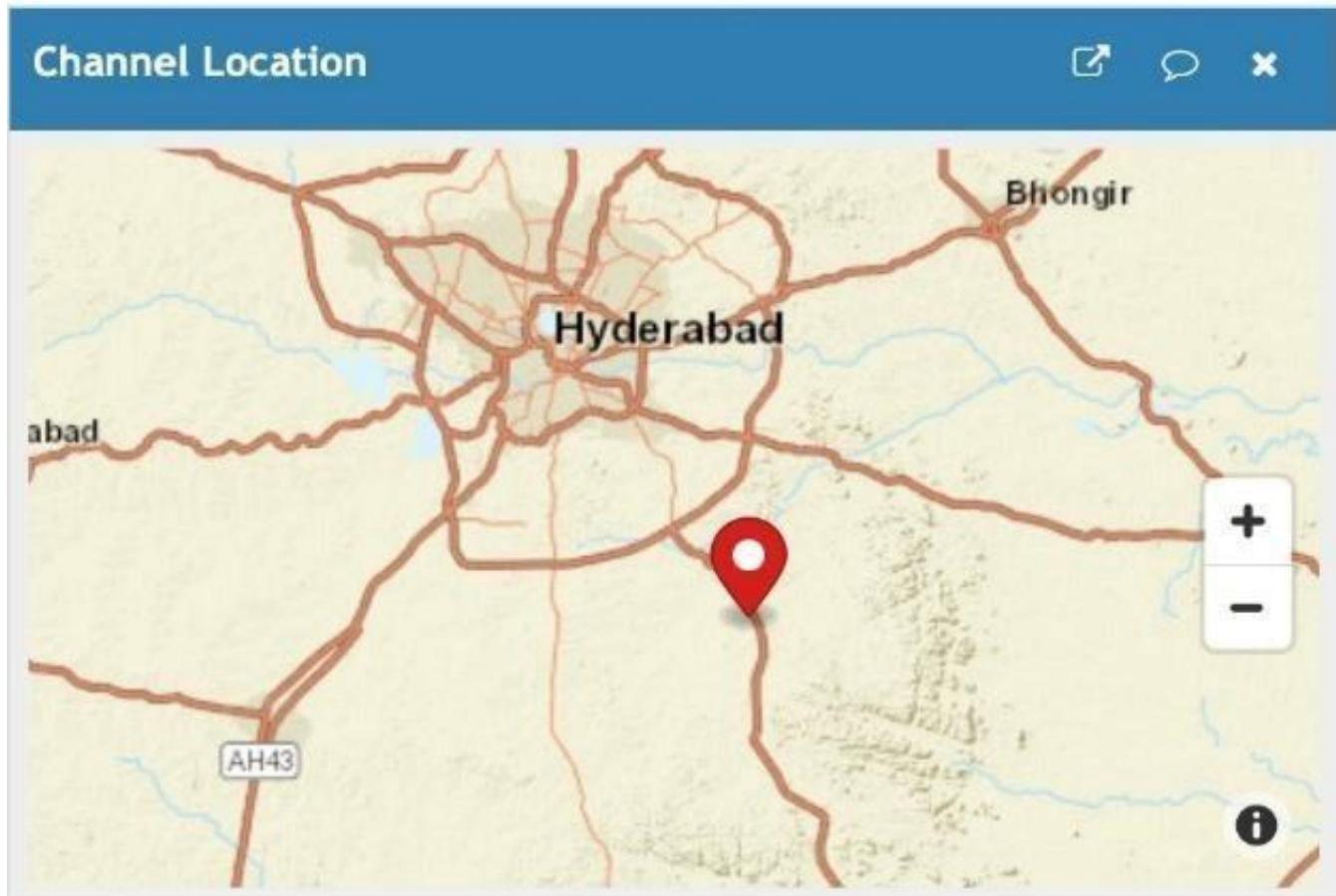

Fig 6: Output of GPS Module

Functional Analysis

Proximity Detection: Forward obstacle detection (2–400 cm) and close-range IR detection (2–30 cm) operating in logical OR configuration.

Location Tracking: GPS coordinate extraction and decimal-degree conversion from NMEA GPRMC sentences.

Cloud Monitoring: ThingSpeak field upload with distance, IR state, GPS latitude/longitude, and fix validity every 30 seconds .

Local Feedback: Four-row OLED display update every 250ms and buzzer tone differentiation between alert categories.

Mechanical Actuation: Stepper motor directional pointer and DC motor vibration confirmation of active GPS fix Comparative Performance Evaluation confirms that the proposed design achieves detection accuracy and GPS positioning performance comparable to other published low-cost assistive designs while delivering substantially lower hardware cost and complete offline resilience.

The 98.6% combined detection accuracy reflects the benefit of dual-sensor coverage. The 5.8-hour battery

endurance on a 2,000 mAh 18650 cell is sufficient for continuous use across a typical outdoor journey with capacity remaining for the return trip.

Experimental Description

The system was evaluated under multiple conditions, including indoor corridors, outdoor pathways, and moderately crowded environments. A total of 10+ trials were conducted to validate obstacle detection performance and GPS tracking accuracy. Results confirm consistent performance with 98.6% detection accuracy and stable cloud communication.

Novelty

The proposed system introduces a unique combination of multi-sensor fusion, IoT-based real-time monitoring, and offline resilience in a single low-cost platform. Unlike existing systems that focus on either obstacle detection or tracking, this work integrates both functionalities while ensuring continuous operation even during network failure. This significantly enhances system reliability and usability.

Limitations

The system depends on Wi-Fi connectivity for IoT functionality, which may not always be available. Battery life is limited to approximately 5.8 hours under continuous operation. GPS accuracy may degrade in indoor or dense urban environments. The system has not yet been extensively validated with visually impaired users.

CONCLUSION

The proposed Low-Cost Multifunctional Assistive Device for visually impaired individuals demonstrates the practical feasibility of integrating multi-modal proximity sensing, GPS location tracking, and IoT cloud monitoring into a single affordable microcontroller-based system. By combining ultrasonic and IR sensors, the system achieves reliable obstacle detection across multiple ranges, while the GPS module enables real-time location tracking for caregiver monitoring through the ThingSpeak cloud platform.

Experimental results confirm that the system achieves a high obstacle detection accuracy of 98.6% and GPS positioning accuracy of approximately 2.3 meters under open-sky conditions. The device maintains a low hardware cost of around ₹2500, making it significantly more accessible compared to existing commercial assistive solutions. The integration of sensor fusion and offline resilience ensures continuous operation even in the absence of network connectivity, thereby improving reliability and user safety.

Despite its advantages, the system has certain limitations, including dependence on Wi-Fi connectivity for IoT functionality, limited battery life of approximately 5.8 hours, and reduced GPS accuracy in indoor or dense urban environments. Additionally, the system has not yet been extensively validated with visually impaired users in real-world scenarios.

Future enhancements can further improve the system by incorporating advanced and intelligent features. AI-driven obstacle classification using camera modules and lightweight machine learning models such as TensorFlow Lite on Pico W can enable contextual awareness by distinguishing different types of obstacles, such as vehicles and static objects. Adaptive feedback mechanisms, including speech-based alerts using audio modules, can improve usability in noisy environments.

Furthermore, the integration of cellular connectivity using GSM/GPRS modules can ensure uninterrupted IoT functionality in areas without Wi-Fi coverage. Expanding obstacle detection through additional sensors positioned at different angles can improve environmental awareness, including detection of steps, edges, and side obstacles. The system can also be enhanced through compact wearable designs using 3D-printed enclosures for real-world deployment.

In addition, future developments may include multi-user monitoring platforms for institutional use and advanced assistive technologies such as haptic feedback systems or augmented reality-based navigation to support complex and dynamic environments. These improvements will further enhance the scalability, usability, and real-world applicability of the proposed system.

REFERENCES

1. World Health Organization, "World Report on Vision," WHO Press, Geneva, Switzerland, 2019.
2. K. Bhowmick and M. K. Hazarika, "An insight into assistive technology for the visually impaired and blind people: State-of-the-art and future trends," *Journal on Technology and Persons with Disabilities*, vol. 5, pp. 226–243, 2017.
3. MathWorks, "ThingSpeak for IoT Projects — Documentation," [Online]. Available: <https://thingspeak.com/docs>, accessed Mar. 2025.
4. J. Madake, S. Bhatlawande, A. Solanke, and S. Shilaskar, "A qualitative and quantitative analysis of research in mobility technologies for visually impaired people," *IEEE Access*, vol. 11, pp. 82496–82520, 2023, doi: 10.1109/ACCESS.2023.3291074.
5. S. Bhatlawande, J. Mahadevappa, J. Mukhopadhyay, M. Biswas, D. Das, and S. Nanda, "Design and development of ultrasonic spectacles and waist-belt for visually impaired and blind persons," *Proc. Inst. Mech. Eng. Part H*, vol. 228, no. 1, pp. 3–13, Jan. 2014.
6. J. Liao, S. Deng, Y. Liu, and Y. Chen, "GPS-based audio navigation system for visually impaired pedestrians," in *Proc. IEEE Conf. Ind. Electron. Appl. (ICIEA)*, Singapore, 2018, pp. 534–538.
7. N. Adnan, S. M. Nordin, and M. A. Bahruddin, "IoT-based caregiver notification system for elderly and visually impaired individuals using GPS and cloud platforms," *J. Telecommun. Electron. Comput. Eng.*, vol. 10, no. 2, pp. 67–73, 2018.
8. K. Manikandan and T. Manikandan, "IoT-based health monitoring and alert system using Raspberry Pi and ThingSpeak platform," *Int. J. Adv. Res. Electr. Electron. Instrum. Eng.*, vol. 7, no. 4, pp. 2133–2139, Apr. 2018.
9. R. Bharani and B. Ramkumar, "Smart cane with obstacle sensing and GPS tracking for visually impaired people," in *Proc. IEEE Int. Conf. Intell. Syst. Control (ISCO)*, Coimbatore, India, 2017, F. Ashiq, M. Asif, M. B. Ahmad, S. Zafar, K. Masood, T. Mahmood, M. T. Mahmood, and I. H. Lee, "CNN-based object recognition and tracking system to assist visually impaired people," *IEEE Access*, vol. 10, pp. 14819–14834, 2022.
10. u-blox AG, "NEO-6 u-blox 6 GPS Modules Data Sheet," Rev. 6, Thalwil, Switzerland, 2011.